

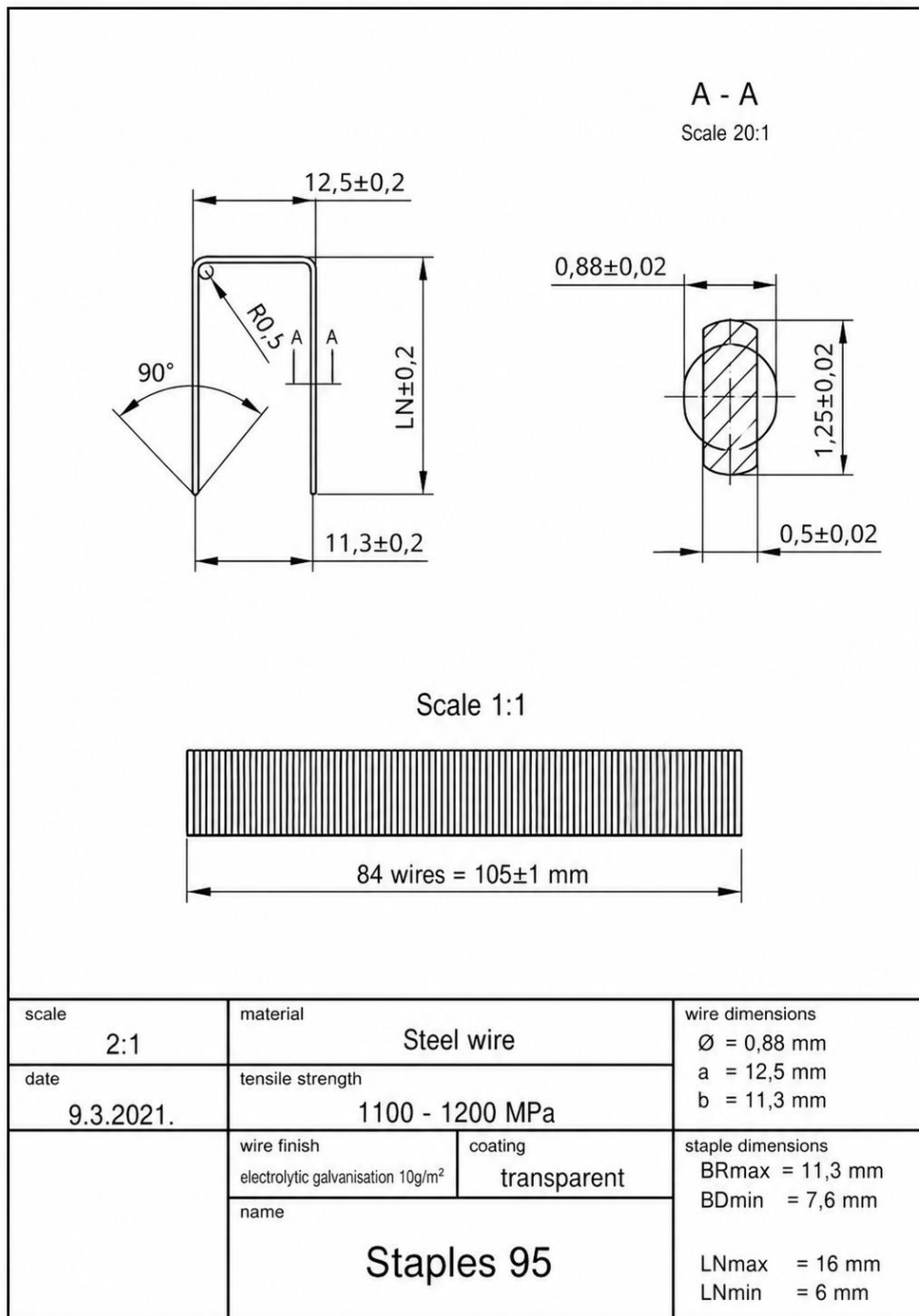

SCHEMA TECNICA PUNTI SERIE 50(95)



Project code: 1H9B29X0613668.NK